

Operational Amplifier, Single, 1 Amplifier, 8 MHz, 2.8 V/ μ s, $\pm 4V$ to $\pm 18V$, DIP, 8 Pins

Manufacturers	Analog Devices, Inc
Package/Case	PDIP-8
Product Type	Amplifier ICs
RoHS	Rohs
Lifecycle	



Images are for reference only

Please submit RFQ for OP27EPZ or [Email to us: sales@ovaga.com](mailto:sales@ovaga.com) We will contact you in 12 hours.

[RFQ](#)

General Description

The OP279 is a dual rail-to-rail, high output current, single supply amplifier. It is designed for low voltage applications that require either current or capacitive load drive capability. The OP279 can sink and source currents of ± 80 mA (typ) and is stable with capacitive loads to 10 nF.

Applications with the benefit from the OP279's high output current include driving headphones, displays, transformers, and power transistors. The powerful output is combined with a unique input stage that maintains very low distortion with wide common-mode range, even in single supply designs.

The OP279 can be used as a buffer to provide much greater drive capability than can usually be provided by CMOS outputs. CMOS ASICs and DACs often have outputs that can swing to both the positive supply and ground, but are incapable of driving greater than a few milliamps.

Bandwidth is typically 5 MHz and the slew rate is 3 V/ μ s, making these amplifiers well suited for single supply applications that require audio bandwidths when used in high gain configurations. Operation is guaranteed from voltages as low as 4.5 V, up to 12 V.

When using the OP279 in +5 volt systems, very good audio performance can be attained. THD is below 0.01% with a 600 Ohm load, and noise is a respectable 21 nV/Hz. Supply current is less than 3.5 mA per amplifier.

The OP279 is available in 8-pin plastic DIP and SO-8 surface mount packages. They are specified over the industrial (-40°C to $+80^{\circ}\text{C}$) temperature range.

Features

Rail-to-Rail Inputs and Outputs

High Output Current: ± 60 mA

Single Supply: 5 V to 12 V

Wide Bandwidth: 5 MHz

High Slew Rate: 3 V/ μ s

Low Distortion: 0.01%

Unity-Gain Stable

No Phase Reversal

Short-Circuit Protected

Drives Capacitive Loads: 10 nF



PIN CONFIGURATIONS

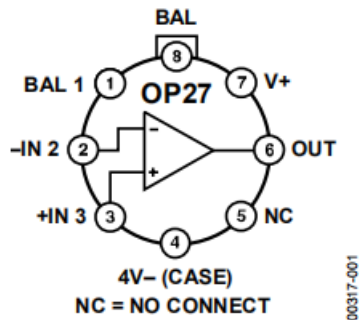

Figure 1. 8-Lead TO-99 (J-Suffix)

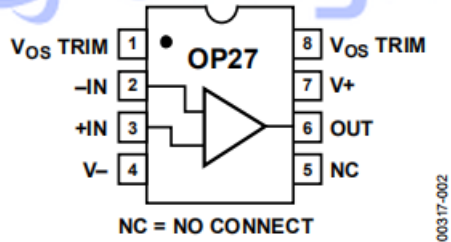
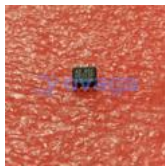

Figure 2. 8-Lead CERDIP – Glass Hermetic Seal (Z-Suffix),
8-Lead PDIP (P-Suffix),
8-Lead SO (S-Suffix)

Related Products



[OP213F](#)

Analog Devices, Inc
SMD/DIP-8/SOP-8

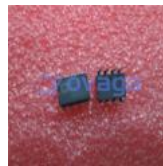

[OP42AZ](#)

Analog Devices, Inc
CDIP-8



[OP27GP](#)

Analog Devices, Inc
PDIP-8

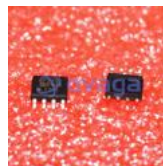

[OP37GS](#)

Analog Devices, Inc
SOIC-8



[OP462GSZ](#)

Analog Devices, Inc
SOIC-14



[OP2177ARM](#)

Analog Devices, Inc
MSOP8



[OP467GPZ](#)

Analog Devices, Inc
PDIP-14



[OP400GPZ](#)

Analog Devices, Inc
PDIP-14